

UC Santa Barbara, SBYC, SBYSF, and PCISA
Gaucha Regatta



SAILING INSTRUCTIONS

1. RULES

1.1 The regatta will be governed by the Racing Rules of Sailing (2009-2012), the prescriptions of U.S. Sailing, the ISSA Procedural Rules as modified by the PCISA, the rules of the CFJ Class (except as modified by the sailing instructions); the Notice of Race and by the sailing instructions, all of which supplement and modify the former.

1.2 All boats must have current registration.

1.3 Class rules requiring CFJ class membership shall not apply.

1.4 All boats must use PCISA issued sails and be entered in a round robin rotation.

2. NOTICES TO COMPETITORS

Notices, scores, and changes will announced verbally at the rotation area or competitors meetings.

3. SIGNALS MADE ASHORE

Signals made ashore will be displayed from an RC boat near the rotation area. During an onshore postponement, boats shall not leave the beach without permission from the race committee.

4. SCHEDULE OF EVENTS

Saturday, March 20, 2010

| | |
|------------------------------|-----------|
| Registration/Boat Inspection | 0900-0945 |
| Skippers Meeting | 1000 |
| Racing Begins | 1100 |

Sunday, March 21, 2010

| | |
|--------------------|------|
| PCISA Mtg. at SBYC | 0930 |
| Racing Begins | 1030 |
| No start after | 1530 |

5. RACING AREAS

The sailing area will be the Santa Barbara Channel within 1 mile of the harbor entrance. Further description will be given at the competitors meeting.

6. COURSES

Courses will be chosen from the attached course chart, and will be hailed before the beginning of each start sequence, and posted on red and white placards.

7. MARKS

Turning marks will be 2 foot yellow tetrahedrons. The offset and start/finish pins will be orange balls.

8. START/FINISH

Start and finish lines will be between an orange ball and the staff displaying an orange flag on the RC boat. Boats that cross this line when not starting or finishing shall be scored DNF without a hearing. The starting sequence shall be as described in Appendix S, with the warning given 3 minutes before the start. Sounds may be whistles or horns.

9. OCS

The RC may attempt to hail the sail number of a boat OCS, but failure to receive or hear the hail shall not be grounds for redress. It is each boat's responsibility to start correctly.

10. CHANGE OF COURSE

The RC may move any mark of the course without signal before a boat has rounded the previous mark.

11. TIME LIMITS

There will be no time limit. However, the RC may choose to finish boats on the course if their position in the race has been established, in order to expedite the next start or rotation.

12. PROTESTS/REDRESS

Varsity protests and request for redress must be filed within 30 minutes of the race committee's return to the dock. Forms will be available at the registration table. All boats must notify the RC of their intent to protest immediately following the finish of the race in which the incident occurred.

13. ROTATIONS

Rotations will be announced at registration. All boats will be entered in a round robin.

14. SCORING

Scoring shall be completed as described in the ISSA Procedural Rules. The race committee may choose to finish boats still racing if their position has been established, to expedite the next race or rotation. Boats that continue to race after such a hail may miss the next start.

15. RECORD OF PARTICIPATION

RP forms must be complete and signed by the end of the event. Forms will be available before the competitors meetings and at the registration desk.

16. SUPPORT BOATS

The host will provide all on-water support. All coaching shall be done from the rotation area, or a similar onshore location.

17. SAFETY

Santa Barbara Channel is an open-ocean venue. Each sailor must provide adequate safety and cold water gear. PFDs must be worn at all times while on the water.

Unprepared teams may be sent to the beach at the discretion of the race committee. There will be no redress for such action.

18. DISCLAIMER OF LIABILITY

Participants in this event compete entirely at their own risk. See Rule 4, Decision to Race. The organizing authority will not accept any liability for material damage or personal injury sustained in conjunction with or prior to, during, or after the regatta.

Course Chart

Courses 1 and 2

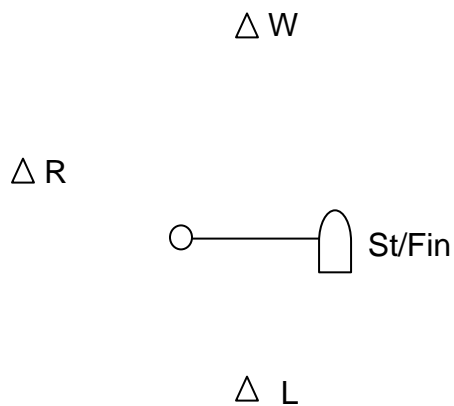

Course 1: St, W, L, Fin
Course 2: St, W, R, L, Fin

Courses 3, 4 and 5



Course 3: St, W/O, Gt, Fin U
Course 4: St, W/O, Gt, W/O, Fin D
Course 5: St, W/O, Gt, W/O, Gt, Fin U

Notes:

- Round all marks to port, except the starboard gate mark.
- Gt denotes a gate, to be rounded inside-out.
- W/O denotes a weather mark followed by an offset mark.
- The Fin U line may use the offset mark as the finish pin if no weather mark is set.